

INSTALLATION INSTRUCTIONS

LOW VOLTAGE LINEAR





INSTALLING LED STRIP LIGHTING:

1. TURN POWER OFF AT CIRCUIT Breaker
SHOCK HAZARD! Turn power OFF at circuit breaker prior to installation to avoid serious injury or death.
2. VERIFY PRODUCT IS CORRECT
Pre-light using the wiring diagrams in this guide to ensure Kelvin temperature (color) is correct. DO NOT connect max runs yet.
3. DETERMINE LOCATION TO INSTALL
Dry-fit the lights to the desired location BEFORE removing the adhesive backing. Refer to the CONFIGURATION GUIDE for a list of products and zone locations.
4. PREP SURFACE
To ensure lasting bond, use the provided alcohol wipe to prep the surface (wall, channel, etc). For slippery surfaces, pre-sand the area before installing the lights or use 3M Primer 94.
5. MOUNT THE STRIP LIGHT
FOR CHANNEL - SEE BELOW. Once fit is confirmed, begin peeling the backing and gently press the strip light into place, slowly working your way towards the end. This process will make it easier to handle the strip light, especially in longer runs.

NOTE: Adhesive MUST BE REMOVED for proper heat dissipation. Do not let the LEDs hang when installing, as this could add stress to the solder connections.

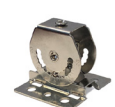
INSTALLING IN CHANNEL:

6. CUT THE CHANNEL
To determine the length, place the LEDs beside the channel, add 1" for the Lead Lock Heat Shrink. Snap the lens and end cap into place and secure with masking tape at the cut mark to protect the lens from cracking. If installing 1707: After cutting channel, remove lens - measure 0.39" from end - then cut lens to account for the end caps. For bendable channel, see step 7g.
Cut using metal rated saw blade. If needed, use a metal file to smooth the edges and wipe away metal or plastic residue to insure a clean install.
7. MOUNT LEDS IN CHANNEL
Center the LEDs starting 1/8" away from the end with the hole.
 - A. CHANNEL WITHOUT CLIPS: Install channel directly to the surface with the provided screws. You will need to pre-drill the holes before installation or use self-tapping screws when installing onto metal.
 - B. CHANNEL WITH CLIPS: Screw clips to the surface at the beginning and end of each section and then about every 1.5 ft in between. For certain channels, you can utilize the clips to connect channel 
 - C. UNIVERSAL CLIPS: Attach the provided channel clips to the Universal Clips. Then install at least four clips for every 2M of channel, to the surface with screws. Snap your channel into the clips and secure the channel by pinching the clips around the channel. 
 - D. MUD-IN CHANNEL: Prep the wall by measuring the channel width and cutting into the drywall. Then, slide the channel in the wall, with the wings resting on the drywall. (Optional: Secure the channel in place by using screws in the mud-in holes.) Then, mud over the wings to secure the channel.
 - E. UNIVERSAL CHANNEL WITH MAGNETS & CONNECTORS: Slide the round magnets into the bottom of the channel. Plan to place 4 magnets for every 2M of channel. Then simply place it onto a magnetic surface. To connect channel for longer runs, slide half of the connector into the bottom of the channel and secure using the screw. Slide the second piece of channel up against the other piece of channel and secure with a screw.
 - F. SUSPENDED CHANNEL: Unscrew Part B to remove the hexagon screw , then put the recessed clip on top and screw back together. Install it to the ceiling by unscrewing Part A and taking the cap and screwing it into place with the long screw provided. Install 3 suspension kits for every 2M. Once the cables are in place and hanging from the ceiling, slide the recessed clips on Part B into the top of the channel. 
 - G. BENDABLE CHANNEL: Start by marking the center and then 1 foot on each side, if bending symmetrically. Use your bending tool, not bending past the bend radius, which can cause buckling or denting. For best results, bend about 4 degrees at a time and roll 6-12" beyond on each side of the center bend. The longer the roll, the less chance of any indentation on the channel. See product spec doc for max bend angle
 - H. CHANNELESS LENS: With Adhesive Backing: Once the LEDs are installed, install the lens by removing the adhesive backing and pressing it into place. Using the screws is optional.

Once the channel is bent to the desired shape, measure and mark where to cut, using metal rated saw blade. Use metal file to smooth edges. Then slide the lens into the channel to determine the length to cut. Use masking tape to prevent the lens from cracking.

INSTALLATION INSTRUCTIONS

LOW VOLTAGE LINEAR



INSTALLING IN CHANNEL CONTINUED:

8. INSTALL LENS

Once the LEDs are in place, install the lens by pressing it into place, starting from one end and working your way to the other, then snap the solid end cap onto the open end.

9. TURN POWER ON AT CIRCUIT BREAKER

Once your LEDs are installed, turn the power on at the circuit breaker. View wiring diagrams or product spec doc.

10. Control your LEDs

If using a controller, refer to the corresponding control instructions or product spec doc.

INSTALLING NEON ROUND OR MINI

1. FOLLOW STEPS 1-3 ON PAGE 1

2. CUT THE CHANNEL FOR NEON

Measure the length of the neon and subtract 3.62" to allow room for the end caps (subtract 3.15" for aqueous neon). Then measure the length of the channel and mark on the channel where you plan to cut.

Cut using a metal rated saw blade. If cut is rough, use a metal file to smooth the edges. Clean any remaining slivers of metal to insure a clean install.

3. MOUNT THE NEON (CHANNEL OR CLIPS)

Install channel or clips directly to the surface with screws. You will need to pre-drill the holes before installation or use self-tapping screws when installing onto metal.

Gently press neon into the channel/clip, where it will lock into place with the clamps. If you need to remove the neon, use a pliers to gently pinch the clamps to pull the neon out.

4. FOLLOW STEPS 9 - 10 ABOVE

Do not attempt to make sharp bends. Excessive or exaggerated bending and twisting can damage the circuit.

NOTE: IP65 is water resistant / protected from water jets or spray at any angle; IP68 is protected from effects of permanent submersion in water up to 13 feet (but not for pools unless UL676 rated). Power supply is NOT. Cutting LEDs in the field may void the UL Certification and Warranty.



⚠ NOVA FLEX WARNINGS & WAIVER

- Any installation of this product should be completed by a professional licensed electrician pursuant to all applicable governing laws, ordinances, regulations, national and local electrical and building codes.
- This is an electronic product which is susceptible to damage if handled incorrectly. Improper soldering or modification may result in a voided warranty. Warranty cases will be made at Nova Flex's discretion based on multiple factors.
- Do not allow product to be punctured or penetrated by foreign objects; this can result in a short circuit.
- Do not connect product directly to a 120V AC power source. For best performance, do not load the DC power source more than 80% of its labeled rating.
- Any use of this product is entirely at your own risk. Failure to utilize and install this product in its proper manner could result in severe injury and/or property damage.
- Keep out of reach of children.

This product is provided by the manufacturer "as is" "with all faults" without any warranties or representations, express or implied, including, but not limited to the warranties of merchantability or fitness for a particular purpose. In no event shall manufacturer be liable for any special, incidental, punitive indirect or consequential damages of any kind. Manufacturer offers this product and the user accepts it subject to the foregoing conditions, which may only be modified in a writing signed by the manufacturer. See complete Terms & Conditions at www.novaflexled.com

Nova Flex retains the right to modify the design of our products at any time as part of the company's continual product improvement program

PROJECT

FIXTURE

PHASE

DATE

Rev: Oct.25.23.10:11

800.595.6302

novaflexled.com

INSTALLATION INSTRUCTIONS

LOW VOLTAGE LINEAR

NOVA FLEX

TROUBLESHOOTING

LEDS NOT ILLUMINATING THE RIGHT COLOR

To properly address this problem, we'll need to see what you are seeing. Take some pictures of the wiring installation where input and output connections meet and be prepared to e-mail them to service@novaflexled.com. Please have your SO number available, which can be located on the white label of the LED strip light. If you are seeing color variations, this could be due to color reflections from surrounding surfaces.



DIM LEDES

It is important to make sure that the project is not too far away from the power supply. Please reference our Voltage Drop Chart to assist in determining the proper gauge wire for your project, if needing to run over 15 ft. The voltage that the LEDs need is low and can diminish over distance due to voltage drop. Refer to the Bill of Material to make sure you are using the proper light/power combination.

- If you are a licensed electrician and have a voltmeter, inspect the current going through the power supply using appropriate safety measures.
- If you are using a dimmer, make sure it's set to the brightest setting.

LEDS NOT TURNING ON

The first thing we recommend is to verify that the lights are hooked up correctly and the polarity is correct. Red=positive / Black=negative. If you have hooked up the lights backwards, don't worry - there have built-in safety measures. If current attempts to run backwards, the LEDs will not turn on.

- If you are a licensed electrician and have a voltmeter, inspect the current going through the power supply using appropriate safety measures.
- If you are using one of our 'quick connect' power supplies, be sure that the barrels are making a proper connection.
- If you are using the RGB strip light series, make sure that the connection has enough wire exposed on the leads going into the controller and they are all the way to the back of the terminals. If there is not enough wire, there won't be a good connection to turn on the lights.

LEDS FLICKERING, PULSING AND/OR ODDLY PUTTING OUT LIGHT

If you are using a dimming power supply, make sure your system is wired to a compatible dimmer switch. Refer to our Spec Sheets for a list of compatible dimming switches. Confirm polarity of wiring, ensuring +/- are connected properly.

- If you are a licensed electrician and have a voltmeter, inspect the current going through the power supply using appropriate safety measures.
- Unplug the project and make sure that the solder connection is secure. Gently wiggle the solder points to make sure that the wires are not falling off of the project. Then plug the project back in and try again.
- If the distance between the power supply and lights is greater than 15 ft, there can be loss of wattage. This can cause flickering.

LEDS NOT STICKING SECURELY

Wipe down the surface using the supplied alcohol wipe to ensure you have a clean surface. If you are still not seeing a desired outcome, we recommend applying some 3M Primer 94 to the surface or purchasing our Hard or Soft LED strip light clips. Our durable plastic clips are designed to make sure that the lighting is securely where you want it to be. The clips need to be nailed or screwed into the surface. If your project has long straight edges with a surface that doesn't take to tape or if you want your project to have a diffused single light effect, we offer aluminum channel. We will supply you with screws and clips to apply to the surface. If none of these options are possible, there's always double-sided tape or silicone to consider.

LEDS TOO HOT

If you're a licensed electrician and have a voltmeter, inspect the current going through your power supply using appropriate safety measures. There should be no more than 24V DC entering the LEDs. While the LEDs produce very little heat, it is important to make sure that the strip light is spaced for proper air movement. LEDs have a max operating temp of 140° for IP65 and 175° for IP68.

LEDS VERY HOT/MELTING

Turn off the lights and call us immediately at 1-800-595-6302. The lights are never supposed to do this.

Nova Flex retains the right to modify the design of our products at any time as part of the company's continual product improvement program

PROJECT

FIXTURE

PHASE

DATE

Rev: Oct.25.23.10:11

800.595.6302

novaflexled.com

INSTALLATION INSTRUCTIONS

LOW VOLTAGE LINEAR



UNIVERSAL DRIVERS STRIP LIGHT: 20 GAUGE WIRE

TRIAC / PHASE CUT DIMMING

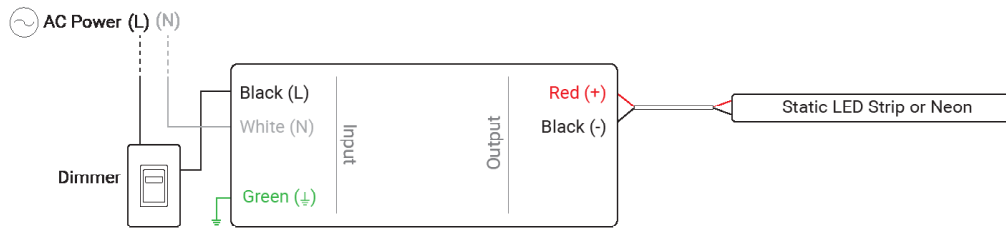

- The Pulse-Width Modulation (PWM) for output voltage can be adjusted through input terminal of the AC phase line(L), by connecting a phase/TRIAC dimmer
- Works with forward phase/leading edge, MLV and reverse phase/trailing edge, ELV, TRIAC dimmers
- Please use dimmers with power ≥ 1.5 times the output power of the driver

0-10V/1-10V DIMMING, WITH DIMMER ON INPUT SIDE

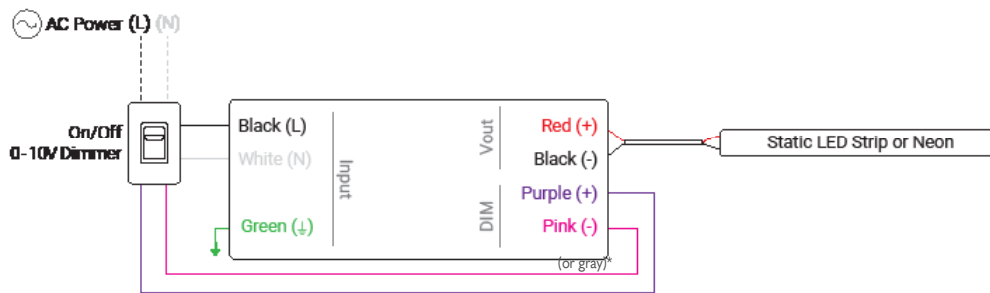

- The 0-10V/1-10V dimmer is on the input side so it can control dimming and on/off functions

*The GRAY wire should only be used for neutral (this wire may be pink). Dimming wires are changing from gray/purple to pink/purple.

0-10V/1-10V DIMMING, WITH ON/OFF SWITCH ON INPUT SIDE

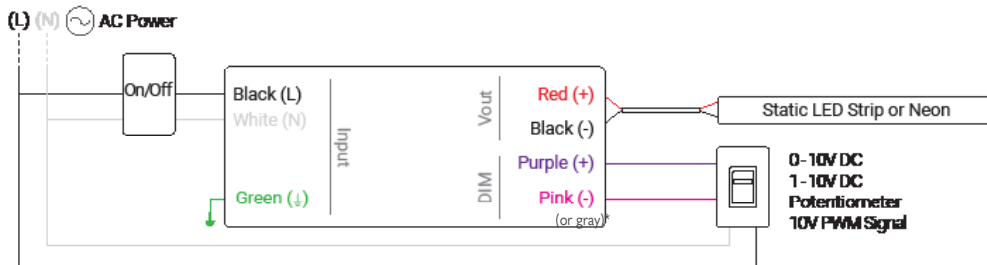

- The on/off switch is on the input side. 0-10V/1-10V controls dimming only, not on/off function

*The GRAY wire should only be used for neutral (this wire may be pink). Dimming wires are changing from gray/purple to pink/purple.

INSTALLATION INSTRUCTIONS

LOW VOLTAGE LINEAR



0-10V DIMMABLE

STRIP LIGHT: 20 GAUGE WIRE

30W OR 96W 0-10V DIMMABLE DRIVER

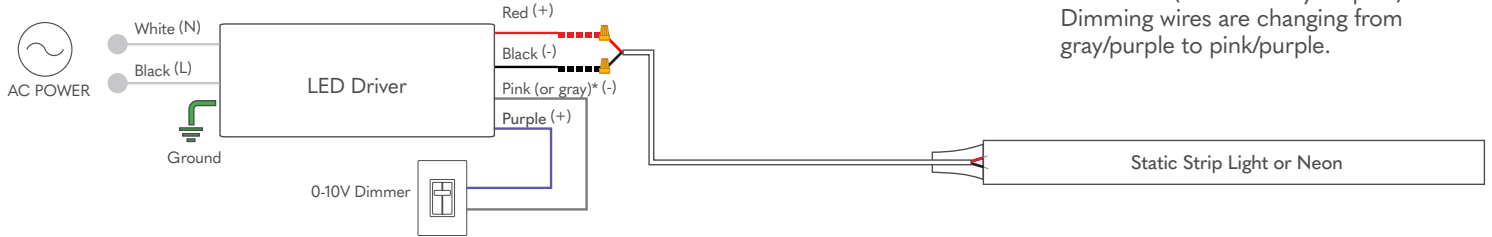

*The GRAY wire should only be used for neutral (this wire may be pink). Dimming wires are changing from gray/purple to pink/purple.

288W 0-10V MULTI-CHANNEL DIMMABLE DRIVER

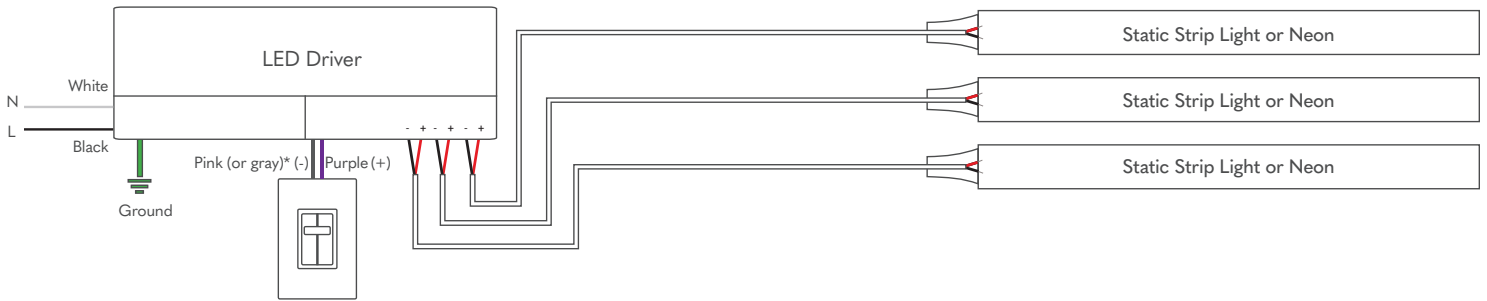

LUTRON

STRIP LIGHT: 20 GAUGE WIRE

Go to lutron.com for more info

WIRING DIAGRAM FOR 3-WIRE CONTROL

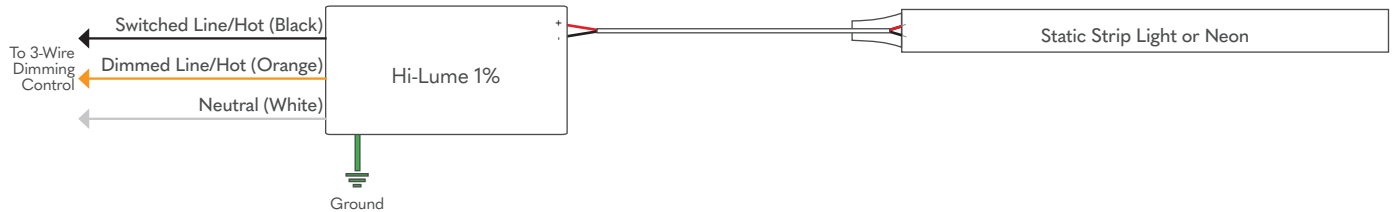

WIRING DIAGRAM FOR ECOSYSTEM DIGITAL CONTROL

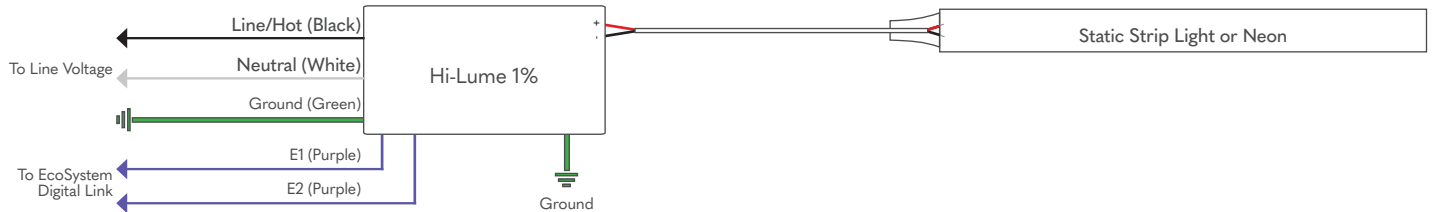

Nova Flex retains the right to modify the design of our products at any time as part of the company's continual product improvement program

PROJECT

FIXTURE

PHASE

DATE

Rev: Oct.25.23.10:11

800.595.6302

novaflexled.com

INSTALLATION INSTRUCTIONS

LOW VOLTAGE LINEAR



HARDWARE, NON-DIMMING STRIP LIGHT: 20 GAUGE WIRE

ELECTRONIC NON-DIMMING DRIVER

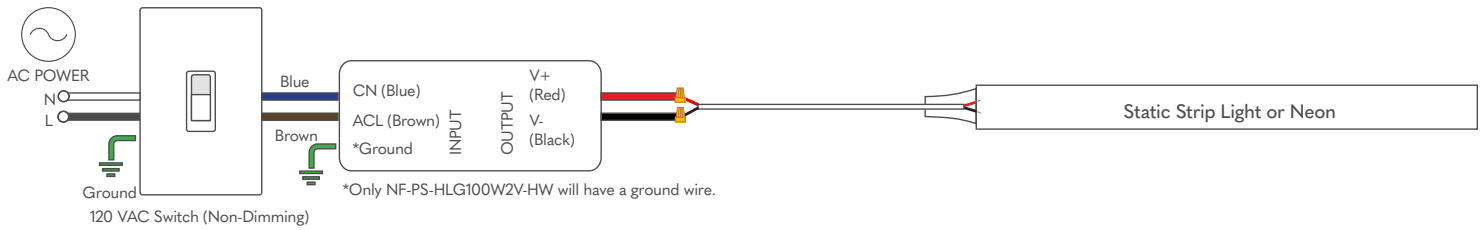

PLUG AND PLAY

STRIP LIGHT: 20 GAUGE WIRE

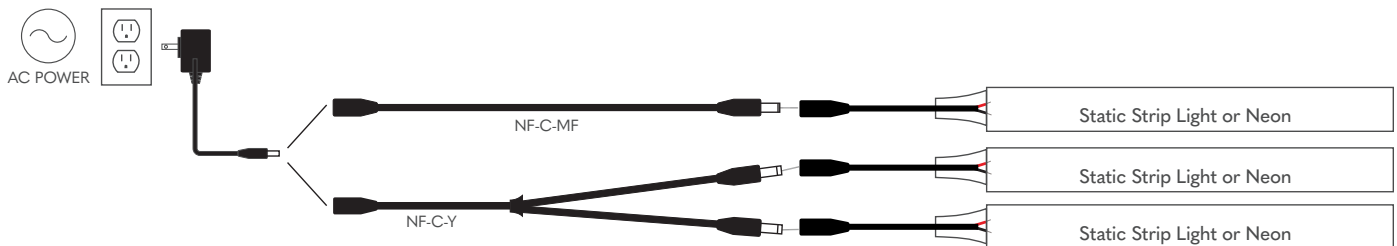

DMX PIXEL DECODER

STRIP LIGHT: 20 GAUGE WIRE

PIXEL DECODER - DRGB STRIP

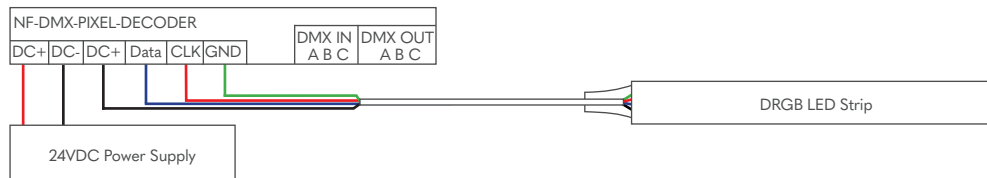

- DC+ Red Wire
- GNC Black & Green Wire
- Data (DI) Blue Wire
- CLK No Connection

PIXEL DECODER - DRGB NEON

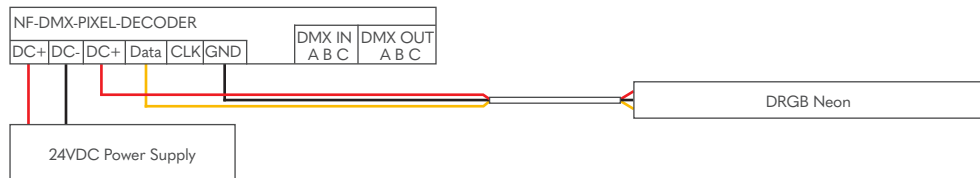

- DC+ Red Wire
- GNC Black Wire
- Data (DI) Yellow Wire
- CLK No Connection

Nova Flex retains the right to modify the design of our products at any time as part of the company's continual product improvement program

PROJECT

FIXTURE

PHASE

DATE

Rev: Oct.25.23.10:11

800.595.6302

novaflexled.com

INSTALLATION INSTRUCTIONS

LOW VOLTAGE LINEAR



S3I WIRELESS RECEIVER

STRIP LIGHT: 20 GAUGE WIRE

STATIC WHITE

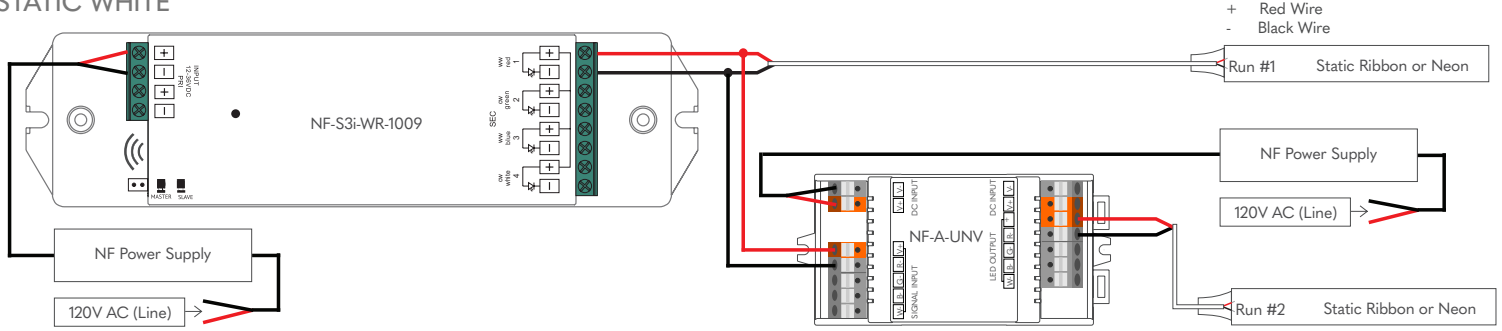

ADJUSTABLE WHITE

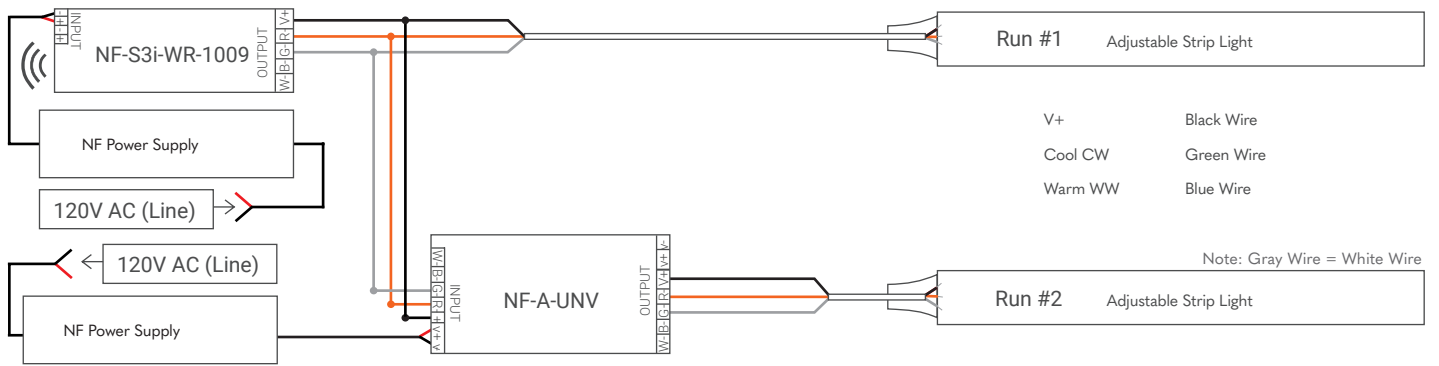

RGB

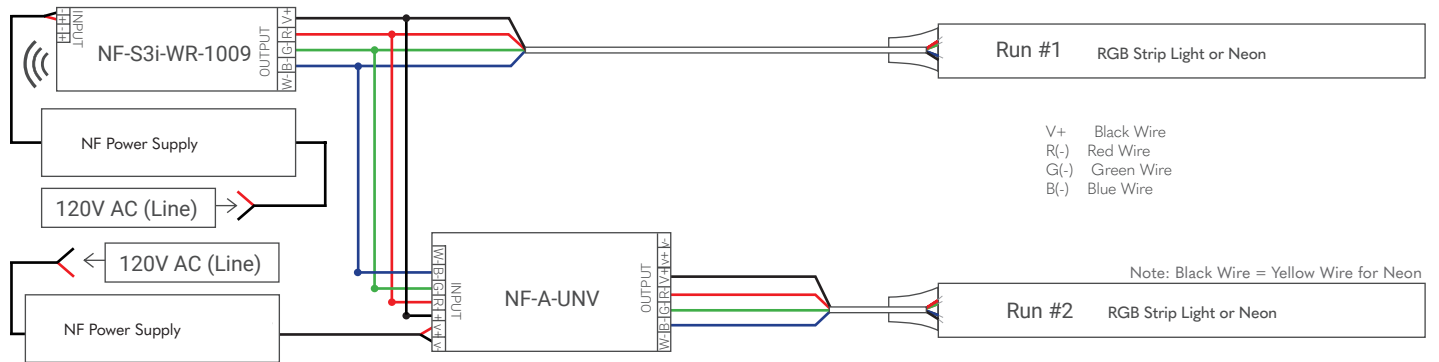

RGBW

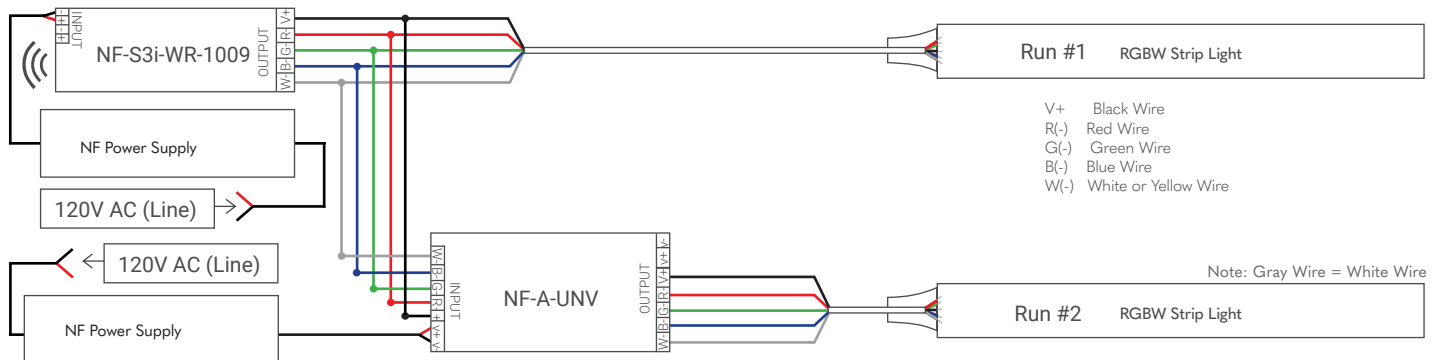

Nova Flex retains the right to modify the design of our products at any time as part of the company's continual product improvement program

PROJECT

FIXTURE

PHASE

DATE

Rev: Oct.25.23.10:11

800.595.6302

novaflexled.com