



Tunable White LED Dimming Module

The SLD DimTW2 is a CV Tunable White LED dimming module. This unique dimming module accepts 0-10V/1-10V control signal and enables smooth, dynamic color temperature shifts of 2000K to 8000K. Depending on the application situation, this plug-and-play dimming module creates eye-catching, color temperature changing effects without color distortion. The efficient Tunable White LED dimming module continues to be a pioneer in the market opening up ease of upgrade and options for color tuning applications that improves the dynamic of light.

SLD-DimTW2

DC/DC (0/1-10V + PWM)
LED Dimming Module



Features

- Wide range DC input 8-48VDC
- Flicker free 0-100% dimming and color temperature changing
- High Efficiency up to 97%
- High precision dimming ratio : >1:1000
- Fully isolated plastic housing
- Comply with EN55015 and FCC Part 15 without additional input filter and capacitors
- Suitable for LED lighting and signage applications
- Compact size, high reliability
- 3 year warranty

Applications

- Architectural Lighting
- Effect & Contour Lighting
- Office General Illumination
- Warehouses
- Street Lighting
- Signage
- Strip Lighting
- Swimming Pools/Fountain lighting



Model	Input Voltage Range	Input Control	Channel Output	Output Voltage Range *	Max. Output Current (A) **	Max Output Power (W)	Power Efficiency (Typ)
SLD-DimTW2	8 - 48 V	2	2	Vin - 0.2~0.5V	5	240	97%

*- SLD-DimTW2 dimming module requires an external CV LED driver, connected to the DC input, and should not exceed the above input voltage range.

Input Specification

Voltage Range	Please refer model table	Input Current	5.1A max (per channel)
Control Voltage	0/1-10VDC Dimmer *The external control source to the SLD-DIM purple and grey control wires should have the capability to sink a min. of 10mA for multiple SLD-DIM modules connected together. * A minimum sink current of 2mA is recommended for a single module	Control Range	0-100%v ~1V = 0% light output 10V =100% light output
Short Circuit Protection	Hiccup-Mode, Auto-Recovery upon removal of short circuit condition.	Over Voltage	Auto Recovery upon input voltage under Vin (max)
Over Temperature Protection	Auto recovery upon operating temperature <105°C	Under voltage Logout	Auto Recovery upon input voltage over Vin (min)

Output Specification

Output Frequency	1kHz PWM	Output Current	5A max. at full load **
Power Efficiency	97% Typ	Dimming Ratio	1:1000

** - SLD-DIM dimming module max. output current is dependent on LED driver output current , which should not exceed the Class 2 maximum of 5A or 100W per output channel.

Environmental Specification

Ambient Temperature	Storage Temp	Relative Humidity
- 20°C - 60°C (Full Load)	- 40°C - 85°C	5% - 95 %

Compliance / Safety

Safety Standards:	UL244A
Weatherability:	IP 65

Mechanical Specification

Power Unit Dimensions	98mm (L) x 44mm (W) x 14.5mm (H)
Case Design/Material	Polycarbonate White
Wire Length	6 inches 152.4mm
Wire Size	a. 18AWG standard, 300V, 105deg C (DC input and Dim Output wires) b.22AWG standard, 300V, 105deg C(0/1-10V control wires)

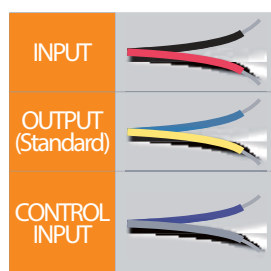

Performance Curve

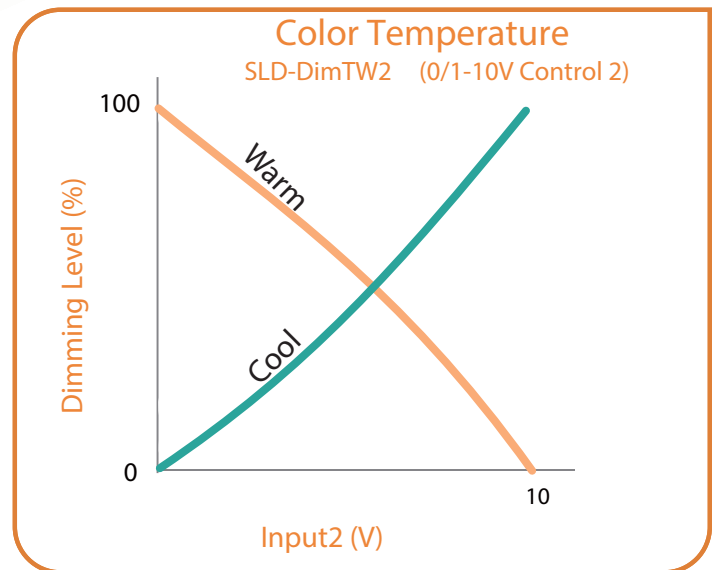
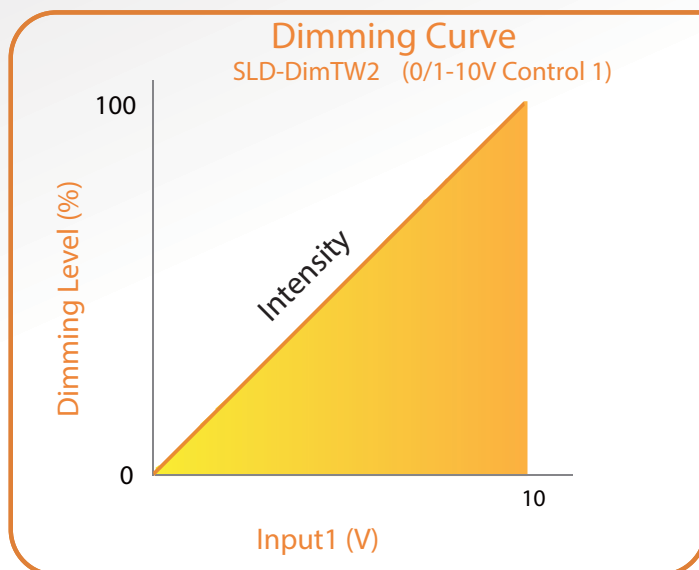
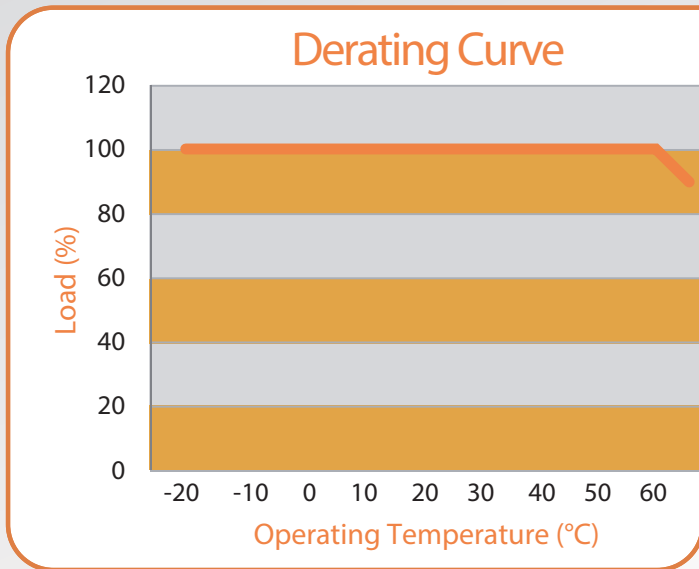

Mechanical Diagram

SLD-DimTW2(Ver. B)

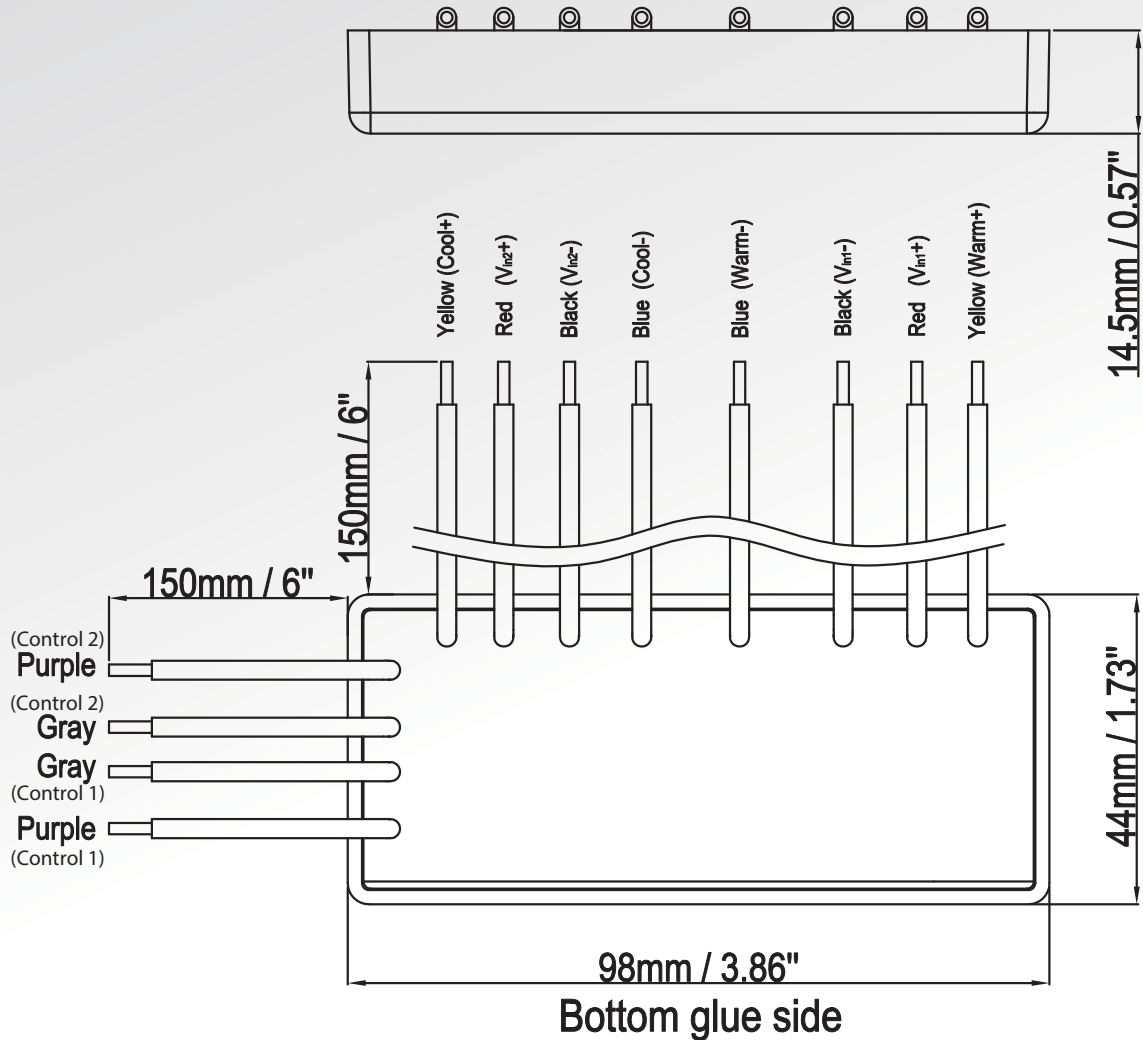

Input Wire		Output Wire		Control Wire	
Black	Vin1 -	Yellow	Warm +	Purple	to 0/1-10V Control 1
Red	Vin1 +	Yellow	Cool +	Gray	to 0/1-10V Control 1
Red	Vin2 +	Blue	Warm -	Purple	to 0/1-10V Control 2
Black	Vin2 -	Blue	Cool -	Gray	to 0/1-10V Control 2

Packing Information

0.10 kg/pcs ; 100pcs/carton;

12.0 kg /carton; L270xW220xH430 (mm)

Wiring Diagrams

SLD-DimTW2

The two Linear strips below may be contained on one 4 conductor SS-TWH

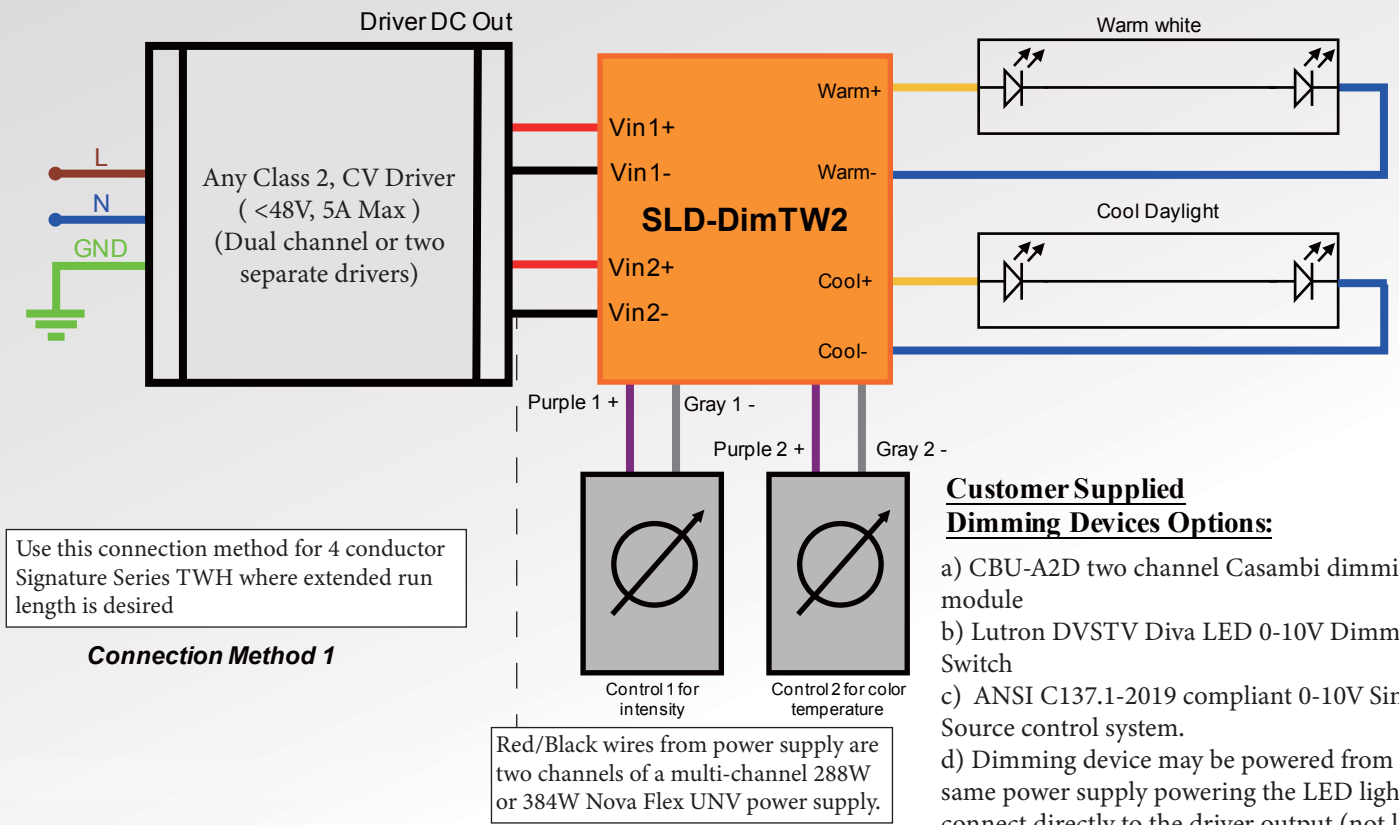

Use this connection method for 4 conductor Signature Series TWH where extended run length is desired

Connection Method 1

Customer Supplied Dimming Devices Options:

- a) CBU-A2D two channel Casambi dimming module
- b) Lutron DVSTV Diva LED 0-10V Dimmer Switch
- c) ANSI C137.1-2019 compliant 0-10V Sink or Source control system.
- d) Dimming device may be powered from the same power supply powering the LED lights; connect directly to the driver output (not load side of module).

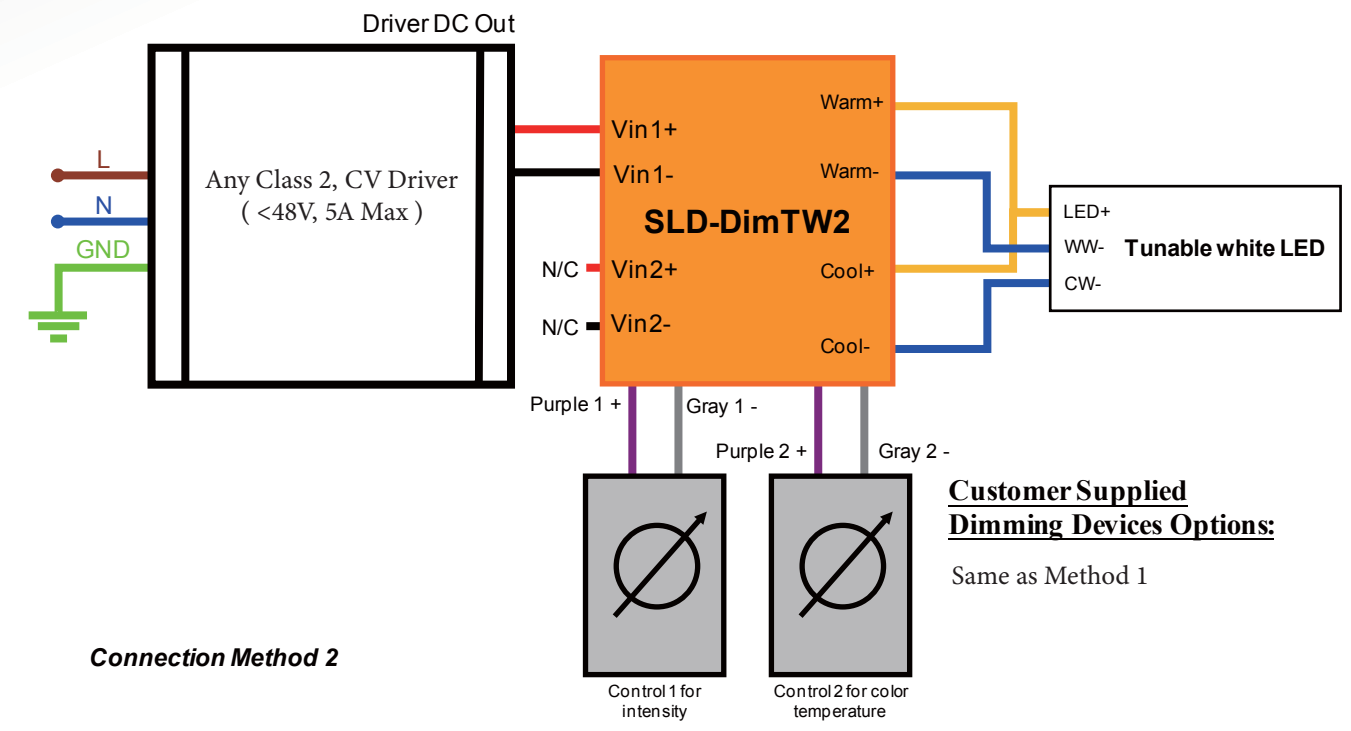

Connection Method 2

Customer Supplied Dimming Devices Options:

Same as Method 1