

# SPEC SHEET - ORDER GUIDE

## ALU-2215 SURFACE



PART NUMBER BUILDER:

Category	Material	Ext Dim	Type	Ext Finish	Lens Finish	Length
CHN	ALU	2215	SUR			2M
				SL	CLR	
				BK	FRS	
				WT <sup>2</sup>	50FR <sup>1</sup>	

**Notes:**

- Configurations have a lead-time of 7-9 weeks
- Configurations have a lead-time of 2-3 weeks
- Lenses are suitable for outdoor use with respect to exposure to ultraviolet light and water exposure in accordance with UL 746C.
- Every 2M of channel comes with 2M of lens, 2 mounting clips, and 2 end caps of choice.

### CHANNEL DIMENSIONS

Dimensions are in MM

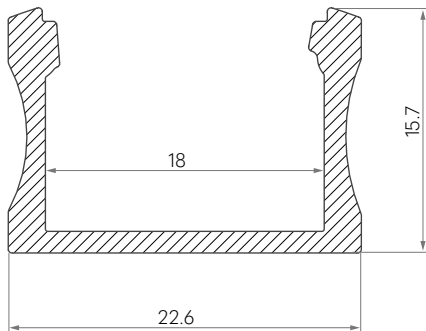

### MOUNTING OPTIONS

#### Mount with Clips

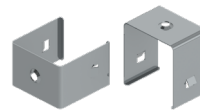

Part Number	Ext Finish
CHN-CLP-2215-SUR	
	SL Silver
	BK Black
	WT <sup>1</sup> White

### ACCESSORIES

#### End Caps

Every 2M of channel comes with 2 end caps of choice.

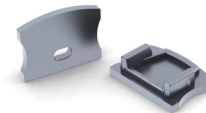

Category	End Cap	Channel	Type	Ext Finish
CHN		2215	SUR	
	ECT			SL
	ECH			BK
				WT <sup>1</sup>

### EXTERIOR FINISH

SL	Silver
BK	Black
WT <sup>2</sup>	White

### LENS FINISH

CLR	Clear Lens
FRS	Frosted Lens
50FR <sup>1</sup>	50% Frosted

Nova Flex LED, LLC. retains the right to modify the design of our products at any time as part of the company's continual product improvement program.