

SPEC SHEET - ORDER GUIDE

ALU-3535 UNIVERSAL



PART NUMBER BUILDER:

Category	Material	Ext Dim	Type	Ext Finish	Lens Finish	Length
CHN	ALU	3535	UNV			2M
				SL	CLR ¹	
				BK ²	FRS	
				WT ²	PRC	
					PRF	

Notes:

- Configurations have a lead-time of 7-9 weeks
- Configurations have a lead-time of 2-3 weeks
- This product is compatible with NF-120V Products
- Lenses are suitable for outdoor use with respect to exposure to ultraviolet light and water exposure in accordance with UL 746C.
- Every 2M of channel comes with 2M of lens, 2 mounting clips, and 2 end caps of choice.

CHANNEL DIMENSIONS

Dimensions are in MM

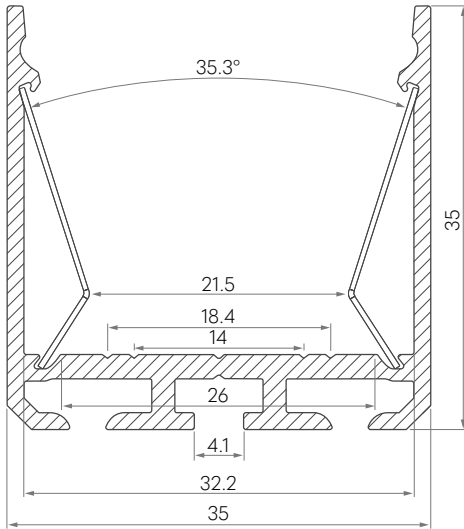

MOUNTING OPTIONS

Mount with Clips

Part Number: **CHN-3535-UNV-CLIP**

Ext Finish	
SL	Silver
BK ¹	Black
WT ¹	White

Part Number: **CHN-CAB-2**

ACCESSORIES

End Caps

Every 2M of channel comes with 2 end caps of choice.



Category	End Cap	Channel	Type	Ext Finish
CHN		3535	UNV	
	ECT	No Hole		SL
	ECM	Mouse Hole		BK ²
	120	120V Hole		WT ²

EXTERIOR FINISH

SL	Silver
BK ²	Black
WT ²	White

LENS FINISH

CLR ¹	Clear Lens
FRS	Frosted Lens
PRC	Prismatic Clear - Premium Lens, available with additional cost
PRF	Prismatic Frosted - Premium Lens, available with additional cost

Reflector

Additional Accessory

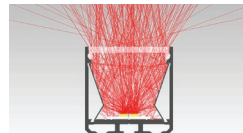

Left and Right Reflectors

Part Number: **CHN-REF-25-2M**

Nova Flex LED, LLC. retains the right to modify the design of our products at any time as part of the company's continual product improvement program.

PROJECT

FIXTURE

PHASE

DATE

Rev: Dec.03.24/10:12

800.595.6302

novaflexled.com