

SPEC SHEET - ORDER GUIDE

ALU-1715 SURFACE



PART NUMBER BUILDER:

Category	Material	Ext Dim	Type	Ext Finish	Lens Finish	Length
CHN	ALU	1715	SUR			2M
				SL	CLR	(6.56')
				BK ²	FRS	(78.74")
				WT ²	50FR ¹	

Notes:

- Configurations have a lead-time of 7-9 weeks
- Configurations have a lead-time of 2-3 weeks
- Lenses are suitable for outdoor use with respect to exposure to ultraviolet light and water exposure in accordance with UL 746C.
- Every 2M of channel comes with 2M of lens, 2 mounting clips, and 2 end caps of choice.

CHANNEL DIMENSIONS

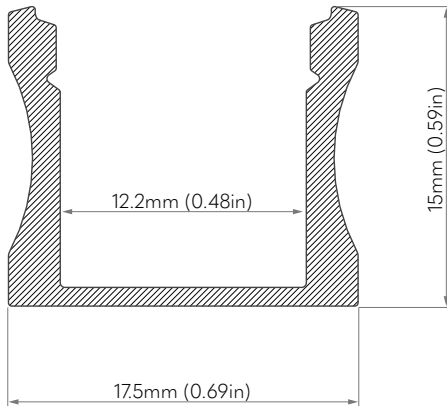

MOUNTING OPTIONS

Mount with Clips

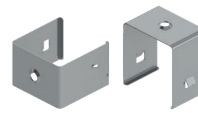

Part Number	Ext Finish
CHN-CLP-1715-SUR	
	SL Silver
	BK ¹ Black
	WT ¹ White

ACCESSORIES

End Caps

Every 2M of channel comes with 2 end caps of choice.



EXTERIOR FINISH

SL	Silver
BK ²	Black
WT ²	White

Category	End Cap	Channel	Type	Ext Finish
CHN		1715	SUR	
	ECT			SL
	ECH			BK ¹
				WT ¹

LENS FINISH

CLR	Clear Lens
FRS	Frosted Lens
50FR ¹	50% Frosted

Nova Flex LED, LLC. retains the right to modify the design of our products at any time as part of the company's continual product improvement program.